

HYDRAULIC FLANGE SPREADER

HexForce Flange spreaders utilize a wedge mechanism inserted between the flanges. As the wedge is forced open, it applies controlled pressure to the flanges, separating them without damaging the components.

This allows for:

- Safe and controlled disassembly of flange connections, minimizing the risk of injury or equipment damage.
- Faster and more efficient separation compared to manual methods.
- Access to components behind the flanges for maintenance or inspection

HF-FS-25EMK

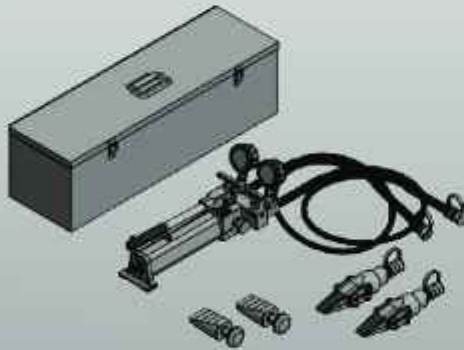

HF-FS-15EK



MODEL	CAPACITY (TON)*	SPREAD (mm)		STROKE (mm)	WEIGHT (Kg)
		MIN.	MAX.		
HF-FS-15EK	15	5	15	25	3.3
HF-FS-15EMK	15 X 2	5	15	25	3.3
HF-FS-25EK	25	7	23	65	7.8
HF-FS-25EMK	25 X 2	7	23	65	7.8